



**KRAEMER**

**Manufacturing**

**1-800-443-6443**

**www.KraemerMFG.COM**

**Click Logo  
to Shop online at our New  
WEB-STORE**

## **“E” TYPE DUST COLLECTORS**

- Sturdy economy units
- 3 filter areas with 1, 2, 3, 4 or 6 filter bags
- For inside use only
- Heavy duty, built to last
- Available in
  - 1 hp, 810 cfm,
  - 2 hp, 1200 cfm,
  - 3 hp, 1604 cfm,
  - 5 hp, 2137 cfm,
  - 7.5hp, 3600 cfm,
  - 10hp, 4900 cfm
 all at 1" s.p.
- Short height units available for under 8 ft ceilings.

- All filter bags are 24" dia. by 72" long with a 6" top inlet
- E-Style collectors come with a TEFC high efficiency motor, three phase (single-phase 110/220 available)
- Units need very little space and are 115" high (for dimensions see reverse)
- All collectors available with silencers (not included)
- 45 imp. gal. or 55 us. gal. drums are available (not included)
- Switches, dust-tight and magnetic are available (not included)



- Single station units can be expanded into 2 or 3 station units if needed for large dust volumes.
- Also available: drums, flex-hose, wall mounting brackets, silencers, clamps, extra filter bags and duct work.

**Used by**

**“THE HOME DEPOT”**



You'll also find our “E” Series dust collectors put to good use in many Home Depot Stores across Canada and USA.



# "E" TYPE DUST COLLECTORS – SPECIFICATIONS

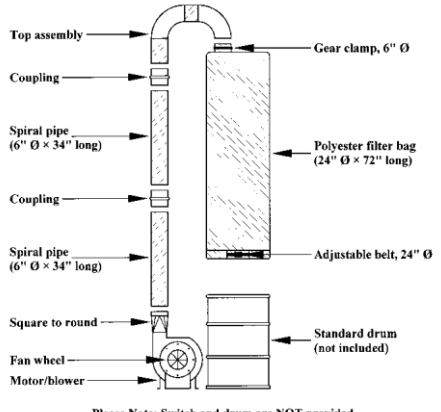

Please Note: Switch and drum are NOT provided

**E 11 & E 21**

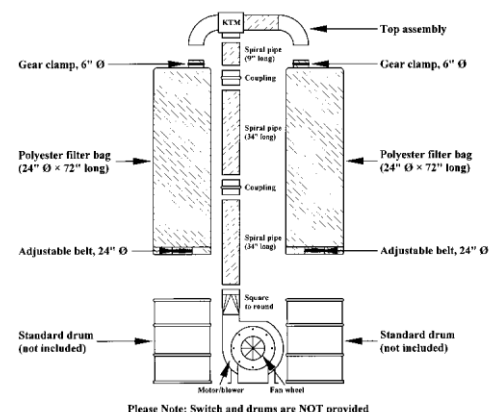

Please Note: Switch and drums are NOT provided

**E 12, E 22, E 32, E 52**

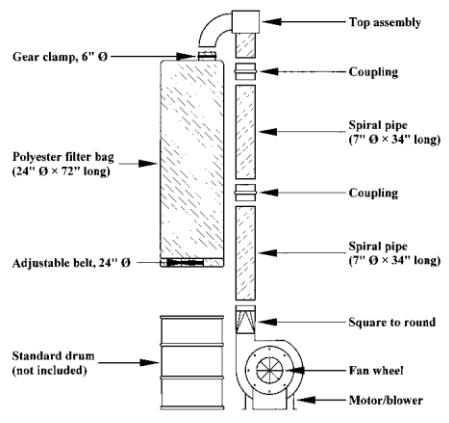

Please Note: Switch and drum are NOT provided

**E 31 & E 51**

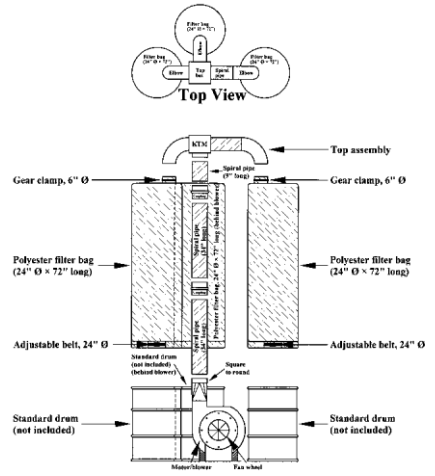

Please Note: Switch and drums are NOT provided

**E 13, E 23, E 33 & E 53, E754 & E106**

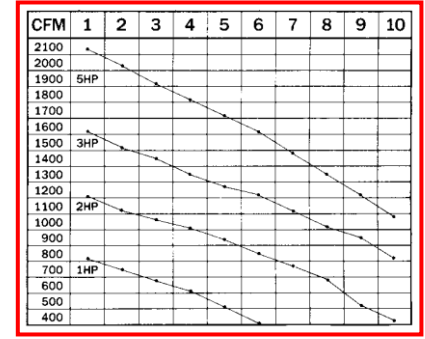

**Performance Data**

MODEL	HP	SIZE (APPROX)	WEIGHT (lbs)	FILTER AREA (sq ft)	INLET SIZE	FILTER BAGS (pcs)
E 11	1	24" X 40" X 115" H	90	39	6"	1
E 12	1	24" X 64" X 115" H	97	78	6"	2
E 13	1	39" X 64" X 115" H	104	117	6"	3
E 21	2	24" X 42" X 115" H	110	39	7"	1
E 22	2	24" X 66" X 115" H	117	78	7"	2
E 23	2	42" X 66" X 115" H	124	117	7"	3

MODEL	HP	SIZE (APPROX)	WEIGHT (lbs)	FILTER AREA (sq ft)	INLET SIZE	FILTER BAGS (pcs)
E 31	3	24" X 44" X 115" H	151	39	7"	1
E 32	3	24" X 68" X 115" H	158	78	7"	2
E 33	3	44" X 68" X 115" H	165	117	7"	3
E 51	5	24" X 48" X 115" H	179	39	8"	1
E 52	5	24" X 72" X 115" H	182	78	8"	2
E 53	5	46" X 72" X 115" H	193	117	8"	3
E 754	7.5	72" X 72" X 115" H	223	156	10"	4
E 106	10	72" X 72" X 115" H	255	234	12"	6

### Applications:

- 1 bag for coarse dust
- 2 bags for mixed dust
- 3 bags for fine dust
- 4 bags for 7.5 hp units
- 6 bags for 10 hp units
- Filter media is polyester beane bag knit, which is washable and dry-cleanable for years of long use.

### Note:

- Listed dimensions are for reference only.
- We reserve the right to make technical improvements.



**KRAEMER MFG**  
 1202 Barton Street, Stoney Creek, Ontario Canada L8E 5R1  
 1-800-443-6443, 1-833-KRAEMER  
 Fax: 1-866-229-5792 [www.kraemermfg.com](http://www.kraemermfg.com)